

# IKA®

## Pilots

Reach highest levels  
in product development  
on a laboratory and  
pilot plant scale



Designed  
to work perfectly



# Why IKA® pilots make you rise to the top.

New products and formulations being developed in laboratories all over the world carry the IKA's signature. When it comes to successive production, IKA® high-duty systems are once again in use on the front line.

Additionally IKA® offers a one-stop, smooth transition of formulations and technologies from laboratory to the large-scale production, thereby solidifying pilot systems as an indispensable link. Findings, acquired in the laboratory, translate from process and recipe development to production scale in a consistently reliable manner.

The pilots that are used during the pilot plant stage play a significant role in determining whether or not a product becomes a success. Here, the process technology to be used is defined, the required machine or system size is determined, and the necessary energy requirements are established. Furthermore, the quality and volume of the raw materials and selection of optional additives, such as emulsifiers, can be determined.

IKA® pilots therefore have a direct influence on the quality and character of the final product.

## IKA® pilots allow you to:

- choose the process technology to be used
- define the required machine and system size
- establish the necessary energy requirements
- determine the quality and volume of the raw materials that will be used
- calculate and define the final product's quality standard
- determine the flow or batch times of the industrial system

IKA® offers the following first-rate products that can be used for numerous mixing tasks in continuous and discontinuous operations:



### Agitators

Reliable helpers get things moving at the pilot plant

IKA® stirrers, designed for the stirring of volumes between laboratory and production amounts, are ideal for speeding up solution processes, for syntheses, temperature exchanges within the medium, and the mixing of easily mixable liquids and solids.



### Batch dispersing machines

Efficient processes for every approach

IKA® batch dispersers are used for applications where conventional stirring is just not enough. For example, when it comes to emulsions and fine suspensions. Thanks to the built-in rotor-stator system, they assure a high product recirculation as well as a good dispersing quality with a comparatively low energy demand.



### Inline dispersing machines

Ideal results, non-stop

They are small, but outfitted just like their respective production machines. The unique design, with a single drive unit, seven exchangeable modules and two upgrade choices enables continuous mixing, emulsifying, suspending, powder incorporation as well as the processing of products during the recirculation operation.



### Laboratory reactors and pilot plants

Achieving a lot while still in the laboratory

IKA® laboratory reactors and pilot plants are just as functional as industrial batch systems. The development of new products or recipe improvements is now easier because everything can be done in one batch: Stirring, dispersing, mixing, heating/cooling and evaporating.



## IKA® agitators

### 4 Reliable helpers get things moving at the pilot plant station

IKA® agitators in pilot size are mainly used for processing of freeflowing mixtures in the lower or medium viscosity range. Depending on the application they can be equipped with propeller, turbine, dissolver, centrifugal, paddle or anchor stirrers. The speed can normally be adjusted by means of a handwheel with indicator scale in the range of 0 to 1200 min<sup>-1</sup>. All product contacting parts are made of high quality stainless steel. A protection against injuries by rotating stirring tools is optionally available. Many of these agitators are also available in Ex-proof execution. The IKA® product range also comprises the matching stands with accessories for fixing of the agitators.



### RW 28 basic

for batches up to 80 ltr (H<sub>2</sub>O)

Powerful, mechanically controlled stirrer. Two speed ranges for highly viscous media and intensive mixing. Push-through mixing tools. Special motor overheating protection by means of self-locking temperature limiter. Stirring shaft protection and clamping fixture to secure bowls are optionally available.

Technical data	
Power supply	220-240 V / 50 Hz
Motor power	220 W
Max. viscosity	50.000 mPa·s
Torque max. at stirring shaft:	
at 60 min <sup>-1</sup>	1.144 Ncm
at 1.000 min <sup>-1</sup>	86 Ncm
Rotat. speed range I (at 50 Hz)	60 – 400 min <sup>-1</sup>
Rotat. speed range II (at 50 Hz)	240 – 1.400 min <sup>-1</sup>
General data	
Dimensions (W x D x H)	123 x 252 x 364 mm
Weight	7,4 kg
Prices EUR	
RW 28 basic (drive)	
Ident. No. 2760000	
R 271 Boss head clamp	
Ident. No. 2664000	
R 2723 Telescopic stand	
Ident. No. 1412100	
R 1385 Propeller stirrer	
Ident. No. 0477700	



R 1385 Propeller stirrer, 3-bladed

R 271 Boss head clamp

R 2723 Telescopic stand

Package (s. figure: drive, R 1385,

R 271, R 2723)

Ident. No. 9019400

## RW 47 D

for batches up to 200 ltr (H<sub>2</sub>O)

The very powerful IKA® stirrer for laboratories, pilot plants and small-scale production. Two speed ranges for highly viscous media and intensive mixing. Cables and plugs not included in the delivery.

Technical data	
Power supply	3 x 400 V / 50 Hz
Motor power	513 W
Max. viscosity	100.000 mPa·s
Torque max. at stirring shaft:	
at 60 min <sup>-1</sup>	4.642 Ncm
at 1.000 min <sup>-1</sup>	285 Ncm
Rotat. speed range I (at 50 Hz)	57 – 275 min <sup>-1</sup>
Rotat. speed range II (at 50 Hz)	275 – 1.300 min <sup>-1</sup>
General data	
Dimensions (W x D x H)	145 x 340 x 445 mm
Weight	15 kg
RW 47 D (drive)	
Ident. No.	1602000
R 2302 Propeller stirrer	
Ident. No.	0739000
R 474 Telescopic stand	
Ident. No.	1643000

Package (s. figure: drive,

**R 2302, R 474)**

Ident. No. 9019500

## RKG-00-Bo 0,25 kW ATEX

for batches up to 80 ltr (H<sub>2</sub>O)

Technical data	
Power supply	3 x 400 V / 50 Hz
Motor power	250 W
Max. viscosity	50.000 mPa·s
Torque at stirring shaft:	
at 20 - 600 min <sup>-1</sup>	approx. 300 Ncm
at 1.200 min <sup>-1</sup>	approx. 150 Ncm
Rotational speed range	20 – 1.200 min <sup>-1</sup>
General data	
Dimensions (W x D x H)	369 x 288 x 537 mm
Weight	13,8 kg
RKG-00-Bo 0,25 kW ATEX (drive)	
Ident. No.	U084463
R 271 Boss head clamp	
Ident. No.	2664000
Adapter for fixing	
Ident. No.	U080254
Stirrer shaft protection	
Ident. No.	U069094
R 1385 Propeller stirrer	
Ident. No.	0477700
R 2723-ATEX Telescopic stand	
Ident. No.	U099027

Package (s. figure: drive, R 271, stirrer shaft protection,

**R 1385, adapter, R 2723-ATEX)**

Ident. No. U098950



## Agitators IKA® TURBOTRON® RKG-00-Bo

*Ex-protected design*

Powerful, mechanically controlled agitators for intensive mixing with approval for use in Ex-Zone 1 (2G), temperature class T3 acc. to the ATEX 95 directive. Suitable for open or pressureless vessels. Exchangeable stirring tools. Cables not included in the delivery.

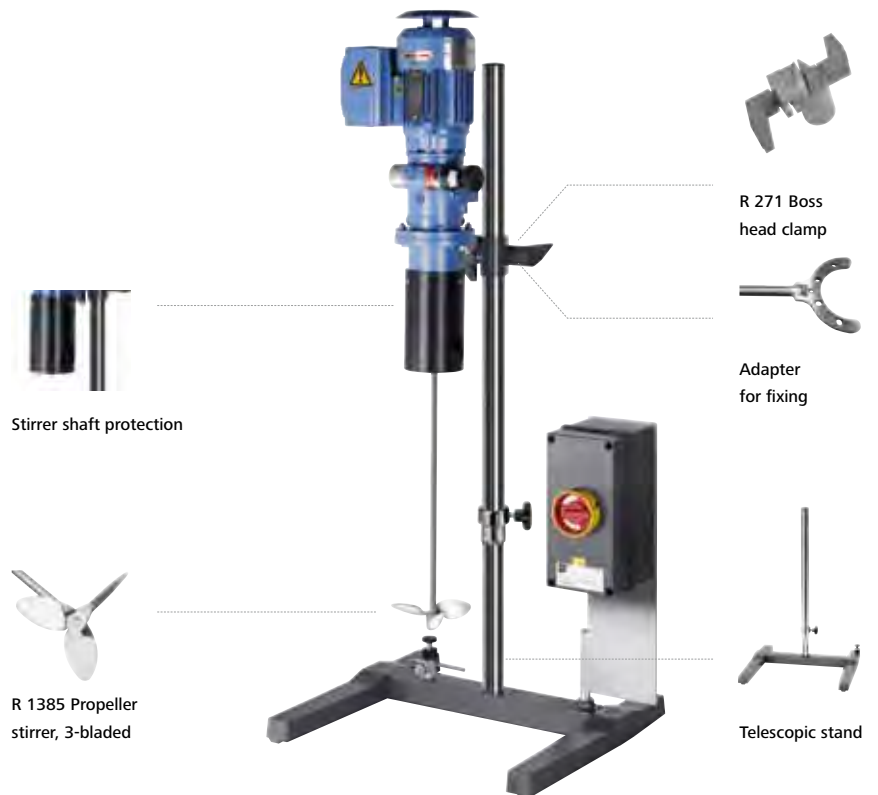

## Magnetic stirrers series MR 1

Powerful magnetic stirrer without heating. Casing and bottom plate made of stainless steel. Infinitely adjustable speed. Magnetic stirring bar IKAFLON® 50 included.



6

### Midi MR 1 digital IKAMAG®

for mixing volumes up to 50 ltr (H<sub>2</sub>O)

Technical data	
Power supply	230 V / 50 Hz
Rotational speed range	0 – 1.000 min <sup>-1</sup>
Speed display	digital
Timer	0 - 56 min
General data	
Dimensions (W x D x H)	360 x 430 x 110 mm
Set-up plate dimensions	350 x 350 mm
Weight	10,7 kg

Ident. No. 2621900

### Maxi MR 1 digital

for mixing volumes up to 150 ltr (H<sub>2</sub>O)

Technical data	
Power supply	230 V / 50 Hz
Rotational speed range	0 – 600 min <sup>-1</sup>
Speed display	digital
Timer	0 - 56 min
General data	
Dimensions (W x D x H)	505 x 585 x 110 mm
Set-up plate dimensions	500 x 500 mm
Weight	16 kg

Ident. No. 2621800

### RKG-00-Bo 0,55 kW ATEX

for batches up to 200 ltr (H<sub>2</sub>O)

Technical data	
Power supply	3 x 400 V / 50 Hz
Motor power	550 W
Max. viscosity	100.000 mPa·s
Torque at stirring shaft:	
at 20 - 600 min <sup>-1</sup>	approx. 600 Ncm
at 1.200 min <sup>-1</sup>	approx. 330 Ncm
Rotational speed range	20 – 1.200 min <sup>-1</sup>
General data	
Dimensions (W x D x H)	186,5 x 333 x 522 mm
Weight	20 kg

RKG-00-Bo 0,55 kW ATEX (drive)

Ident. No. U082491

Adapter for fixing

Ident. No. U082537

Stirrer shaft protection

Ident. No. U069094

R 2302 Propeller stirrer

Ident. No. 0739000

R 474-ATEX Telescopic stand

Ident. No. U092603

Package (s. figure: drive, stirrer shaft protection, R 2302, adapter, R 474-ATEX)

Ident. No. U098955



Adapter for fixing



R 2302 Propeller stirrer, 4-bladed



Agitator, telescopic stand, stirrer shaft protection

A scientist in a white lab coat is focused on adjusting a piece of industrial machinery. The machine consists of several stainless steel cylindrical tanks connected by pipes and valves. The scientist is pointing at a component of the machine. The background is a blurred industrial or laboratory environment with various pipes and equipment.

### **IKA® pilots allow you to:**

- choose the process technology to be used
- define the required machine and system size
- establish the necessary energy requirements
- determine the quality and volume of the raw materials that will be used
- calculate and define the final product's quality standard
- determine the flow or batch times of the industrial system

## IKA® batch dispersing machines

Efficient processes for every approach

Dispersing machines are ideal for materials that cannot be mixed. What a stirrer could not mix in hours, can be dispersed in just a few minutes with a batch disperser. The effectiveness of IKA® dispersing machines is based on the rotor-stator principle. The rotor's high circumferential speeds create the shear forces, which are required by solid particles or liquid drops to lead to their reduction. This is how emulsions and suspensions are created. IKA® offers dispersing machines for batches from 2 l up to 500 l with matching stands and optimal accessories.



### T 65 D ULTRA-TURRAX®

for volumes from 2 up to 50 ltr (H<sub>2</sub>O)

High-performance T 65 D dispersing instrument has been designed for typical pilot plant stations applications. Suitable for mixing, emulsifying and dispersing of freeflowing resp. liquid media in a batch system. Powerful three phase asynchron motor. Three rotor-stator configurations for a variety of applications optionally available. Plug-in connectors facilitate exchange of dispersing elements. Cables and plugs not included in the delivery.

Technical data	
Power supply	3 x 400 V / 50 Hz
Motor power	1,8 kW
Max. viscosity	5.000 mPa·s
Temperature range	0 -180°C
Shaft length	520 mm
Rotational speed	7.200 min <sup>-1</sup>
Circumferential speed	21,9 m/s
General data	
Dimensions (W x D x H)	190 x 580 x 380 mm
Weight	28 kg
T 65 D (drive)	
Ident. No.	1602800
Telescopic stand T 653	
Ident. No.	1608000
S 65 KG-HH-G 65 G	
Ident. No.	8005500
	0



S 65 KG-HH-G-65 G  
Dispersing tool



T 653 Telescopic stand



Package (s. figure: drive, S 65 KG-HH-G-65 G,  
stand T 653)

Ident. No. 9019600

## Batch dispersing machines IKA® ULTRA-TURRAX® UTC

High efficiency dispersion machine for the production of emulsions and suspensions. The KT-version<sup>1</sup> is designed for inclined or vertical installation in open vessels. Cables not included in the delivery.

### UTC T 80/2-KT (w/o figure)

for batches from 25 up to 150 ltr (H<sub>2</sub>O)

Powerful three phase asynchron motor with integrated frequency converter and potentiometer for speed adjustment.

Technical data	
Power supply	3 x 380-420 V / 50 Hz
Motor power	3 kW
Max. viscosity	5.000 mPa·s
Temperature range <sup>2</sup>	0 -120°C
Shaft length standard	650 mm
Rotational speed range	1.200 - 5.200 min <sup>-1</sup>
Circumferential speed	5 - 17 m/s
General data	
Dimensions (W x D x H)	250 x 348 x 1073 mm
Weight	35 kg
UTC 80-KT (drive)	
Ident. No. U098962	
T 2 Dispersing tool	
Ident. No. S073331 + S073332	
UTC T 80/2-KT (drive + T 2)	
Ident. No. U098985	
SFH 75 Mobile stand	
Ident. No. U091783	

#### Package (w/o figure: UTC T 80/2-KT, stand SFH 75)

Ident. No. U098963

<sup>1</sup> On request the KD-version is available for closed vessels (up to 10 bar).  
<sup>2</sup> Machines for operation in the temperature range from -40°C to 160°C are also available.  
<sup>3</sup> Execution for operation via frequency converter as well as electric control optionally possible



### UTC T 115/4-KT ATEX

Ex-protected design

for batches up to 500 ltr (H<sub>2</sub>O)

Approval for use in the Ex-Zone 1 (2G), temperature class T3 acc. ATEX 95

Technical data	
Power supply	3 x 380-420 V / 50 Hz
Motor power	3 kW
Max. viscosity	5.000 mPa·s
Temperature range <sup>2</sup>	0 -120°C
Shaft length standard	965 mm
Rotational speed <sup>3</sup>	3.000 min <sup>-1</sup>
Circumferential speed	15 m/s
General data	
Dimensions (W x D x H)	250 x 250 x 1353 mm
Weight	45 kg
UTC 115-KT ATEX (drive)	
Ident. No. U098964	
T 4 Dispersing tool	
Ident. No. S000867 + S000912	
UTC T 115/4-KT ATEX (drive + T 4)	
Ident. No. U098986	
SFH 150 Mobile stand	
Ident. No. S090947	

#### Package (s. figure: UTC T 115/4-KT, stand SFH 150)

Ident. No. U098965

On request extension of the delivery with electric control.

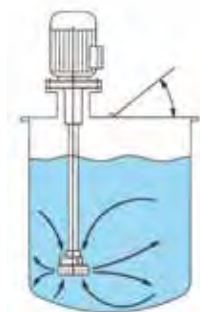
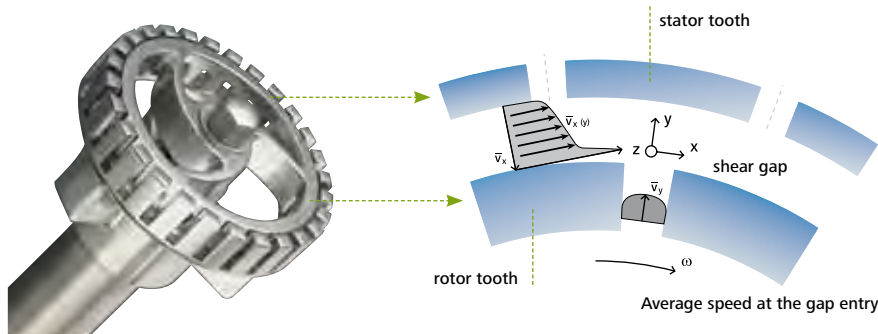

Due to the high rotational speed of the rotor, the medium to be processed is drawn axially into the dispersion head and then forced radially through the slots in the rotor/stator arrangement. The high accelerations acting on the material produce extremely

strong shear and thrust forces. In addition, high turbulence occurs in the shear gap between rotor and stator, which provides optimum mixing of the suspension.

# IKA® inline dispersing machines

10 Ideal results, non-stop

IKA® stands for the development of continuous mixing processes. Saving time, money, and resources while achieving an increased and stable product quality are the advantages offered to you by IKA® inline dispersing machines. The magic LAB®, LABOR-PILOT and PROCESS-PILOT machines are perfectly suited for product development and process optimization and stand out by using the same specific energy input achieved by IKA® inline machines with higher flow rates.

They allow for coarse and fine dispersions to be produced, as well as for powder to be fed into the liquid in a lump and dust free manner and to then be homogeneously mixed. The available accessories allow for these inline machines to be turned into laboratory and pilot mixing systems.



## IKA® inline machine PROCESS-PILOT in recirculation mode

Mounting example

# One machine for many mixing tasks.



- with double acting mechanical seal
- for operation under pressure up to 10 bar and vacuum
- for works at elevated temperatures
- Ex-protected design available

## IKA® magic LAB® 2000/03

Small inline dispersing laboratory machine for the production of emulsions and suspensions with extension capabilities for specific mixing tasks in the continuous and recirculation operation. Control and info center for adjustment and indication of speed, torque and temperature. Double-walled working chamber. Module ULTRA-TURRAX® UTL with rotor-stator system 4M. All metal parts in contact with the product are made of stainless steel. Temperature sensor PT 100, transport box with wheels and drawers for various modules, telescopic handle and built-in power supply are included.

Optional: Software labworldsoft® for the control of the machine magic LAB® from the PC, additional modules and tools, peripherals for extension into a batch plant.

## IKA® LABOR-PILOT 2000/04

Inline dispersing machine in pilot size with upscale possibilities on the production scale. Three phase asynchronous motor with V-belt drive. PTFE shaft seal. All metal parts in contact with the product are made of stainless steel. CIP-/SIP-capable. Standard execution with module UTL: Single stage dispersing chamber including rotor-stator system 4M. Exchangeable modules for special mixing tasks as well as accessories for extension into a system working in recirculation available. Can be delivered with on/off switch or with LABOR-PILOT-CONTROLLER for variable speed adjustment.

## IKA® PROCESS-PILOT 2000/04

Inline dispersing machine in pilot size; suitable for working under vacuum / pressure and at elevated temperatures (when using optional temperature-resistant materials). Equipped with double mechanical seal in cartridge design. This allows, in addition to other LABOR-PILOT-modules, the use of the CMS module for easy and dust-free suction of powders into liquids in batch operation. A locking pressure system guarantees safe working even at dry run. Standard execution with module ULTRA-TURRAX® UTL. Can be delivered with on/off switch or with PROCESS-PILOT-CONTROLLER for variable speed adjustment.

Technical data	
Power supply	230 V / 50 Hz
Motor power	900 W
Temperature long / short time operation	80°C / 120°C
Max. process pressure	2,5 bar
Standard rotational speed	16.000 min <sup>-1</sup>
Adjustable rotational speed range	3.000 - 26.000 min <sup>-1</sup>
Circumferential speed	23 m/s
Flow capacity (at standard speed)	130 ltr/h (H <sub>2</sub> O)
General data	
Dimensions basic machine (W x D x H)	170 x 270 x 215 mm
Weight basic machine	7 kg
Dimensions transport box (W x D x H)	350 x 460 x 560 mm
Weight basic machine in transport box	20 kg

Technical data	
Power supply	3 x 380 - 420 V / 50 Hz
Motor power	1,5 kW
Max. admissible temperature	120°C
Max. process pressure	3 bar
Rotational speed	8.050 min <sup>-1</sup>
Circumferential speed	23 m/s
Flow capacity	approx. 500 ltr/h (H <sub>2</sub> O)
General data	
Dimensions (W x D x H)	450 x 250 x 350 mm
Weight	36 kg

Technical data	
Power supply	3 x 380 - 420 V / 50 Hz
Motor power	2,2 kW
Max. admissible temperature	120°C
Max. process pressure	10 bar
Rotational speed	8.050 min <sup>-1</sup>
Circumferential speed	23 m/s
Flow capacity	approx. 500 ltr/h (H <sub>2</sub> O)
General data	
Dimensions (W x D x H)	425 x 250 x 900 mm
Weight	53 kg

Ident. No. U078310

Ident. No. T055396

Ident. No. T058102

Available also in Ex-protected design

Technical data	LABOR-PILOT-CONTROLLER	PROCESS-PILOT-CONTROLLER
Power	2,2 kW	4 kW
Frequency range	20 - 87 Hz	20 - 87 Hz
Rotational speed range (drive + controller)	3.170 - 13.789 min <sup>-1</sup>	3.170 - 13.789 min <sup>-1</sup>
Circumferential speed (drive + controller)	9,4 - 41 m/s	9,4 - 41 m/s
Ident. No.	T055171	T058761



## Module DISPAX-REACTOR® DR

Three-stage dispersing for manufacturing of fine emulsions and suspensions.

Technical data (at 50 Hz)	magic LAB®	LABOR-PILOT	PROCESS-PILOT
Flow rate	80 ltr/h (H <sub>2</sub> O)	210 ltr/h (H <sub>2</sub> O)	210 ltr/h (H <sub>2</sub> O)
Standard rotational speed	16.000 min <sup>-1</sup>	8.050 min <sup>-1</sup>	8.050 min <sup>-1</sup>
Circumferential speed*	23 m/s	23 m/s	23 m/s
Ident. No.	U078352	T055013	T058133



## Module Colloid mill MK

Wet-milling by means of spiral gearing milling tool. Production of colloidal solutions (finest suspensions) and emulsions. Adjustable flow rate and friction by setting the gap between the rotor and stator.

Technical data (at 50 Hz)	magic LAB®	LABOR-PILOT	PROCESS-PILOT
Flow rate**	200 ltr/h (H <sub>2</sub> O)	1.500 ltr/h (H <sub>2</sub> O)	1.500 ltr/h (H <sub>2</sub> O)
Standard rotational speed	16.000 min <sup>-1</sup>	8.050 min <sup>-1</sup>	8.050 min <sup>-1</sup>
Circumferential speed*	23 m/s	23 m/s	23 m/s
Ident. No.	U076662	T054917	T058583



## Module Cone mill MKO

Wet-milling as with the MK-module. The cones are furnished with an abrasion-resistant tungsten carbide-cobalt coating. Narrowest grinding gap enables producing of even finer suspensions.

Technical data (at 50 Hz)	magic LAB®	LABOR-PILOT	PROCESS-PILOT
Flow rate**	25 ltr/h (H <sub>2</sub> O)	75 ltr/h (H <sub>2</sub> O)	75 ltr/h (H <sub>2</sub> O)
Standard rotational speed	16.000 min <sup>-1</sup>	8.050 min <sup>-1</sup>	8.050 min <sup>-1</sup>
Circumferential speed*	23 m/s	23 m/s	23 m/s
Ident. No.	U079664	T061069	T061674



## Module CMS

Suction of solids into fluids in the recirculation process. Free from lumps and dust processing of powders and granules. Energy-efficient homogeneous mixing.

Technical data (at 50 Hz)	magic LAB®	PROCESS-PILOT***
Flow rate	1.000 ltr/h (H <sub>2</sub> O)	6.500 ltr/h (H <sub>2</sub> O)
Standard rotational speed	11.000 min <sup>-1</sup>	8.050 min <sup>-1</sup>
Circumferential speed*	27 m/s	27 m/s
Ident. No.	U075333	T061272



## Module MHD (mixing, homogenising, dispersing)

Continuous mixing and dispersion of powders in liquids. Patented process. Fast and homogeneous mixing in only one passage, avoiding agglomerates. Solids content up to 80%.

Technical data (at 50 Hz)	magic LAB®	LABOR-PILOT	PROCESS-PILOT
Flow rate	60 ltr/h (H <sub>2</sub> O)	200 ltr/h (H <sub>2</sub> O)	200 ltr/h (H <sub>2</sub> O)
Standard rotational speed	11.000 min <sup>-1</sup>	8.050 min <sup>-1</sup>	8.050 min <sup>-1</sup>
Circumferential speed*	23 m/s	23 m/s	23 m/s
Ident. No.	U075262	T055142	T058148

\* At standard rotational speed and 50 Hz \*\* at minimal gap between the rotor and stator  
 \*\*\* Only with 4 kW motor

## Mounting examples



magic LAB® as a mobile inline machine with transport box



magic LAB® with module Micro-Plant 1 ltr for recirculation process in the open vessel



magic LAB® with module Micro-Plant 2 ltr for recirculation process in the closed vessel



magic LAB® with module CMS and accessories for powder incorporation into liquid in recirculation mode



magic LAB® for batch process as ULTRA-TURRAX®

## High pressure homogenizer HPH 2000/04

High energy density and highly turbulent flow at the valve outlet. Particle and droplet size reduction to the nano range. Optimal setting of homogenizing effect by infinite adjustment of the valve gap as well as optional adjustment of the speed. Versions with one or two pistons with correspondingly different capacity are available.

All metal parts in contact with the product are made of stainless steel. The standard version is equipped with an on / off switch. Variable speed control via a HPH-CONTROLLER optionally available. Execution acc. to GMP as well as CIP or SIP capability on request.

13

### HPH 2000/04-SH5

Technical data	
Power supply	3 x 400 V / 50 Hz
Motor power	1,5 kW
Max. admissible temperature	60°C
Homogenizing pressure max.	2.000 bar
Min. feeding volume	10 mltr
Rotor rotational speed (at 50 Hz)	344 min <sup>-1</sup>
No. of pistons	1
Piston diameter	5 mm
Flow rate (H <sub>2</sub> O)	3 ltr/h
General data	
Dimensions (W x D x H)	286 x 639 x 509 mm
Weight	36 kg

Ident. No U068906



### HPH 2000/04-DH5

Technical data	
Power supply	3 x 400 V / 50 Hz
Motor power	1,5 kW
Max. admissible temperature	60°C
Homogenizing pressure max.	2.000 bar
Min. feeding volume	20 mltr
Rotor rotational speed (at 50 Hz)	344 min <sup>-1</sup>
No. of pistons	2
Piston diameter	5 mm
Flow rate (H <sub>2</sub> O)	6 ltr/h
General data	
Dimensions (W x D x H)	284 x 656 x 568 mm
Weight	36 kg

Ident. No U071735



### HPH-CONTROLLER

Technical data	
Power	1,5 kW
Frequency range	20 - 50 Hz
General data	
Dimensions (W x D x H)	200 x 310 x 405 mm
Weight	17 kg

Ident. No U071728



# IKA® laboratory reactors and pilot plants

14 Achieving a lot while still in the laboratory

Whether you need a system for chemical processes or would like to optimize mixing, dispersing and drying processes, IKA® offers all this in one package. IKA® laboratory reactor LR-2.ST was designed for usage covering a broad spectrum of process parameters, which you can measure and control. The new IKA® MicroPlant MP 2 combines diverse mixing technologies as well as innovative drying. The pilot plant Master Plant MP 10 was designed not only for mixing and dispersing, but also for the effective suction of solid and liquid additives. The pilot plant MP 10, as well as the larger IKA® Master Plant production plants, come with a patented scalable dispersing machine, which enables the production of high-quality emulsions and suspensions in just a few passages.

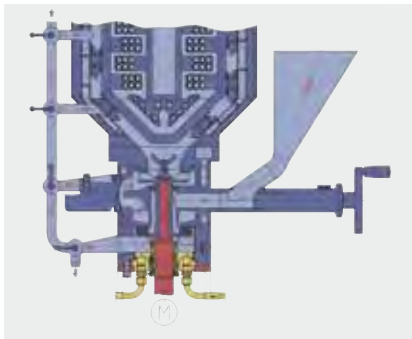

Cross section DBI / Circulation loop

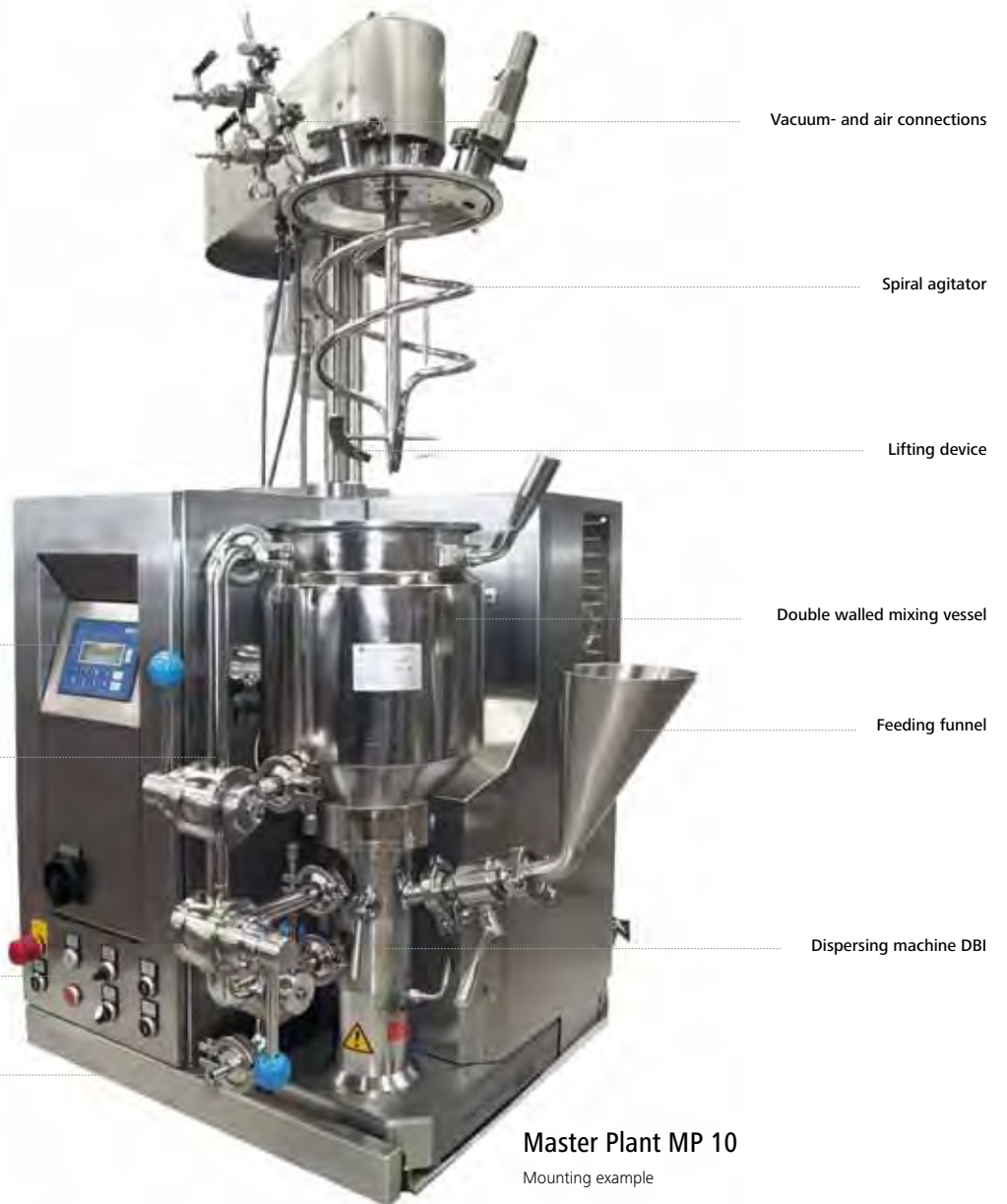

Master Plant MP 10

Mounting example

## Master Plant MP 10

Ideal and compact laboratory and pilot plant for mixing and dispersing in batch. The innovative patented mixing concept assures the highest product quality and an extreme reduction of the output time.

The Master Plant MP 10 is consisting of:

- Heatable / coolable vessel
- Lifting device for vessel cover together with the stirrer
- Heatable / coolable agitator with movable scrapers
- Dispersing machine type DBI 2000/4\* that combines pumping, sucking, mixing, dispersing and CIP
- Circulation loop with selective short or long circuits
- Feeding funnel for liquid or solid additives with manual piston valve
- PROCESS-PILOT-CONTROLLER

Vertical and horizontal mixing. Infinitely adjustable stirrer and disperser speed. Feeding of solid or liquid additives directly into the dispersing chamber without applying vacuum in the vessel. Dispersing machine with double-acting mechanical seal and choice (valve) between gentle pumping and energy-intensive dispersing. Special Ex-proof version of the system MP 10 on request.

\* Machines of type DBI 2000 are separately deliverable for your existing vessels or plants

Technical data	
Power supply	3 x 400 V / 50 Hz
Useful volume	1,5 - 10 ltr
Admissible process temperature	-10 up to 150°C
Max. working vacuum / pressure	10 mbar / 2,5 bar
Max. viscosity	100.000 mPa·s
Frequency range	20 - 60 Hz
Motor power agitator	0,18 kW
Rotational speed range agitator	48 - 144 min <sup>-1</sup>
Motor power disperser	4 kW
Rotat. speed range disperser	3.160 – 9.480 min <sup>-1</sup>
Max. flow capacity of the DBI during dispersing	2.000 ltr/h
Max flow capacity of the DBI as pump with max. speed	6.000 ltr/h
General data	
Dimensions (W x D x H)	945 x 920 x 1.065 mm
Height with open vessel	1.515 mm
Weight	330 kg

### Master Plant MP 10, version 1

(Vessel with discharge valve, lifting device, spiral agitator)

Ident. No. U098988

### Master Plant MP 10, version 2

(Vessel, lifting device, spiral agitator, dispersing machine DBI, circulation loop, 1 feeding funnel, controller)

Ident. No. U084530

Also in Ex-protected design deliverable



Spiral agitator

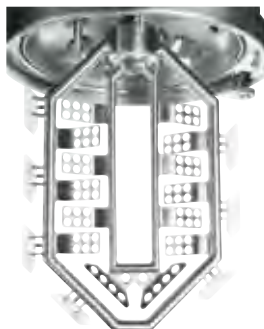

Counter rotating agitator for mixing of high viscous products

## Laboratory reactor LR-2.ST

Modular design laboratory reactor for optimization and simulation of various chemical reactions as well as for mixing and homogenizing processes in a laboratory scale.

LR-2.ST laboratory system consisting of:

- Stand system
- Laboratory stirring unit EUROSTAR power control-visc P7 with high torque
- Anchor stirrer LR 2000.11 with flow borings
- Safety shutdown
- Reactor cover

In the free connections of the reactor cover a dispersing unit (ULTRA-TURRAX®), temperature sensors, flow breakers and other equipment can be installed.

Suitable for vacuum operation. Seals in contact with the product are made of solvent- resp. temperature-resistant perfluoroelastomer (FFPM). Infinitely adjustable speed. Integrated torque trend display for the measurement of viscosity changes. Through control actuated by microprocessor the set speed is held constant, even under load.

Technical data	
Power supply	230 V / 50 Hz
Useful volume	0,5 - 2 ltr
Max. process temperature	230°C
Admissible vacuum	25 mbar
Max. viscosity	150.000 mPa·s
Motor power agitator	130 W
Rotational speed range	8 - 290 min <sup>-1</sup>
General data	
Dimensions (W x D x H)	460 x 430 x 1.240 mm
Weight	25 kg



### Package 1

(LR-2.ST with single walled reactor vessel LR 2.1)



Ident. No. 9008400

### Package 2

(LR-2.ST with double walled reactor vessel LR 2000.1)



Ident. No. 9008500

### Package 3

(LR-2.ST with double walled reactor vessel LR 2000.2, incl. bottom discharge valve)



Ident. No. 9008600